

DATE PRINTED: 3/28/2013

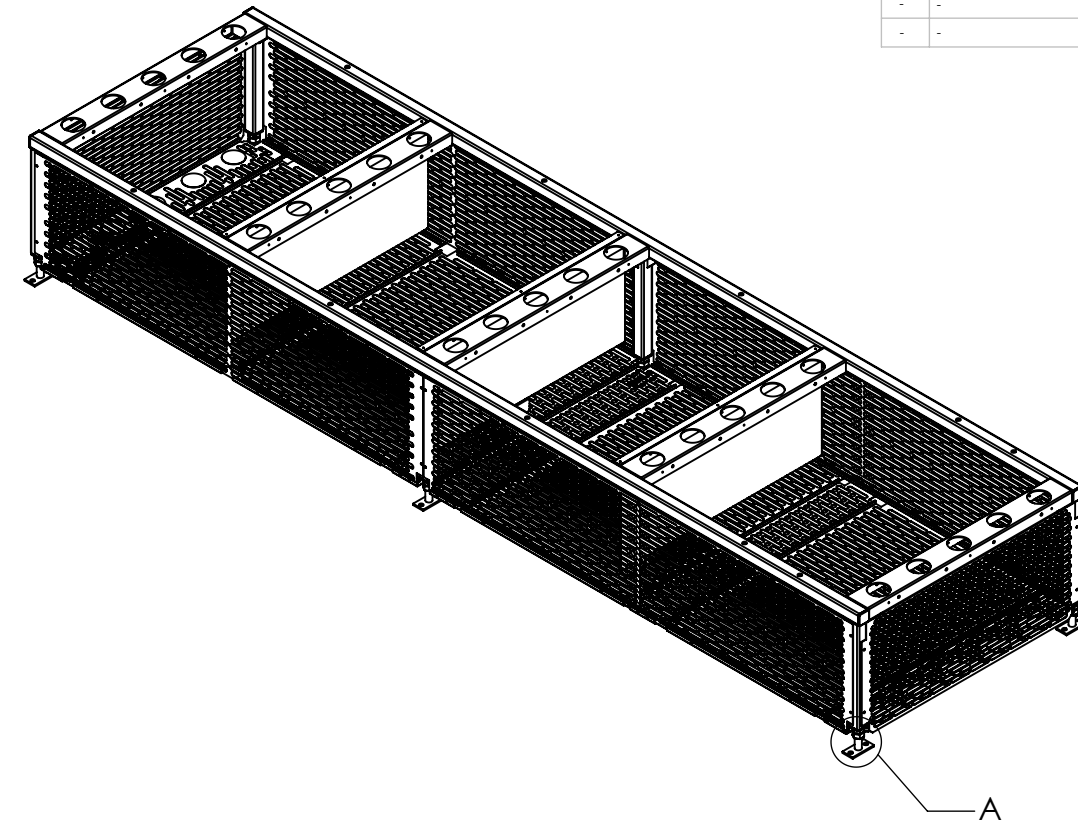

REVISIONS			
REV.	DESCRIPTION	DATE	APPROVED
-	-	-	-
-	-	-	-

NOTES:

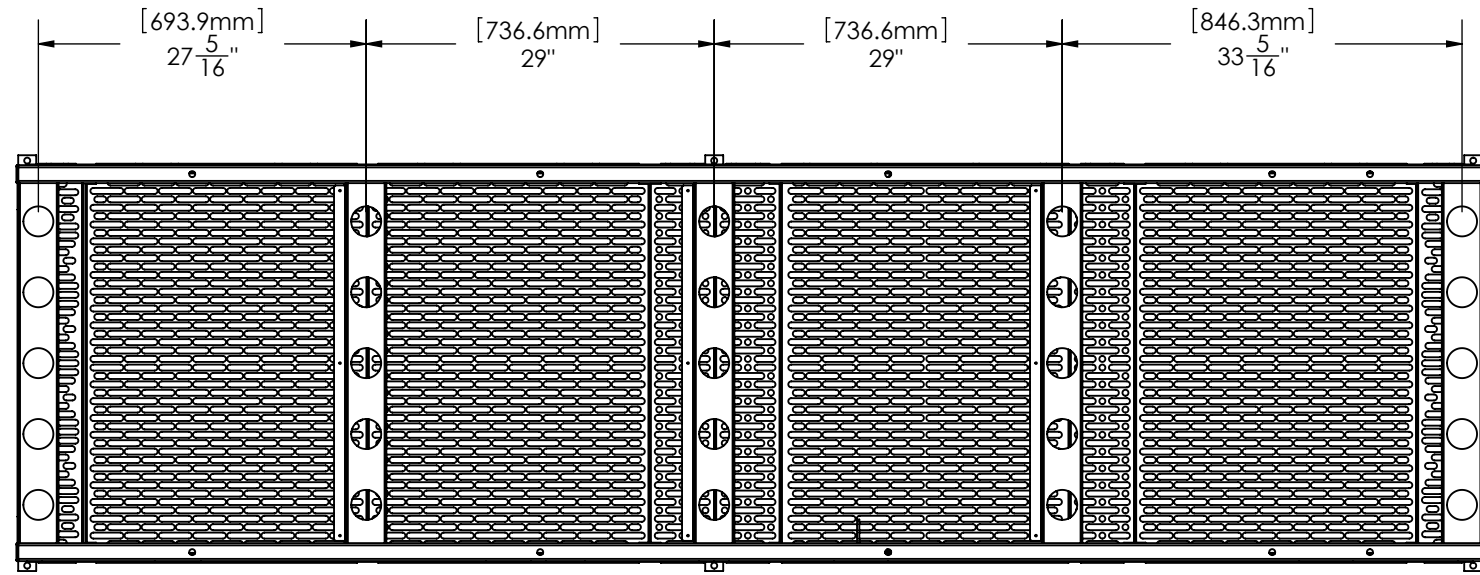
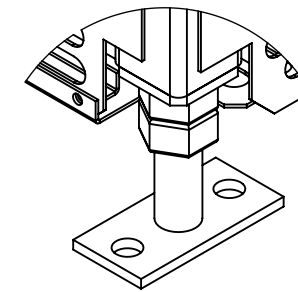
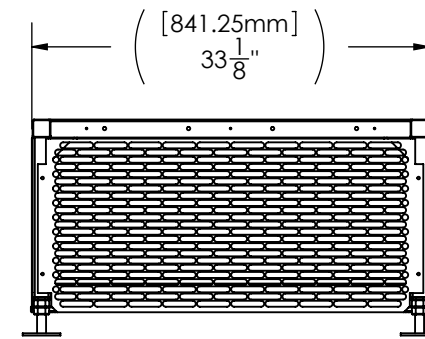
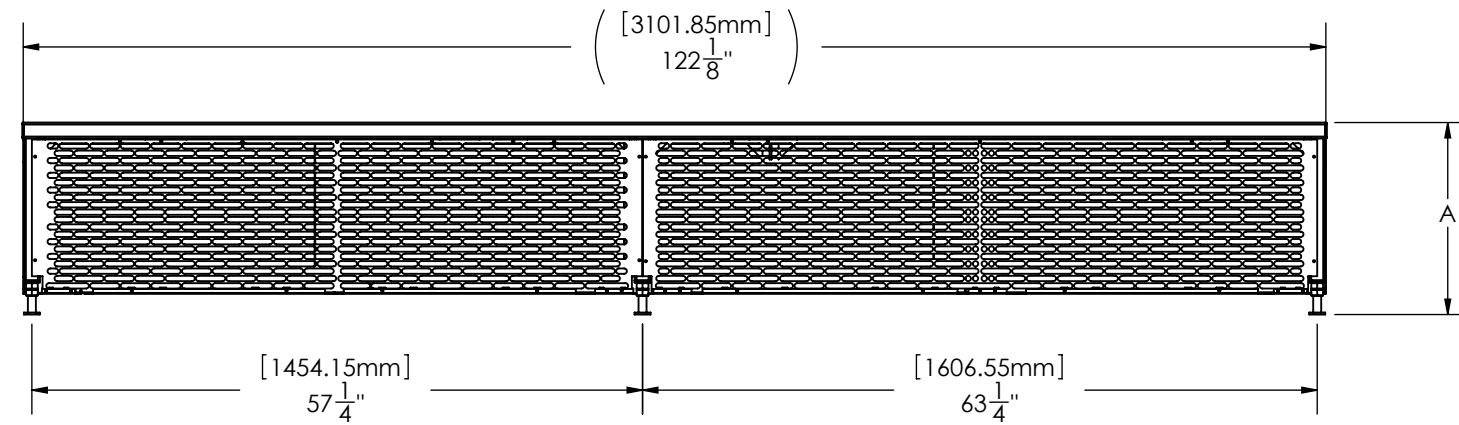

DETAIL A
SCALE 1 : 3

A (HEIGHT)	WELDMENT, PART NUMBER	ASSEMBLY, PART NUMBER
18"	780-100-0086	580-120-0018-18
24"	780-100-0096	580-120-0018-24

CONFIDENTIAL: THE COPYRIGHT OF THIS DOCUMENT IS RESERVED BY CLIMATEWORX. THIS DOCUMENT IS ISSUED ON THE CONDITION THAT IT IS NOT COPIED, REPRODUCED OR DISCLOSED TO ANY OTHER PARTY WITHOUT WRITTEN CONSENT OF CLIMATEWORX.

UNLESS OTHERWISE SPECIFIED
DIMENSIONS ARE IN INCHES
TOLERANCES:
FRACTIONAL ± 1/8
ANGULAR: ± 0.5° BEND ± 2°
DECIMAL
XXX = ± .010
XX = ± .020
X = ± .030
HOLE DIA. +.003/- .000



BY		DATE
DRAWN	I.Z.	02/16/2010
CHECKED	P.S.	02/16/2010
CNC PROGRAM		

FINISH:	X	
MATERIAL	N/A	THICKNESS N/A

FINAL ASSEMBLY FLOOR STAND, DOWN FLOW, CHILLED WATER COOLING ONLY, 12"-24", 119 TO 136 KW, WITH OSHA GUARD	
PART NAME	SPDF-O-J
SIZE	DWG. NO. SPDF-O-J
BD	N/A
K	
SCALE:	1:20
SHEET	1 OF 2

REV.
SEE TABLE

DATE PRINTED: 3/28/2013

REVISIONS			
REV.	DESCRIPTION	DATE	APPROVED
-	-	-	-
-	-	-	-

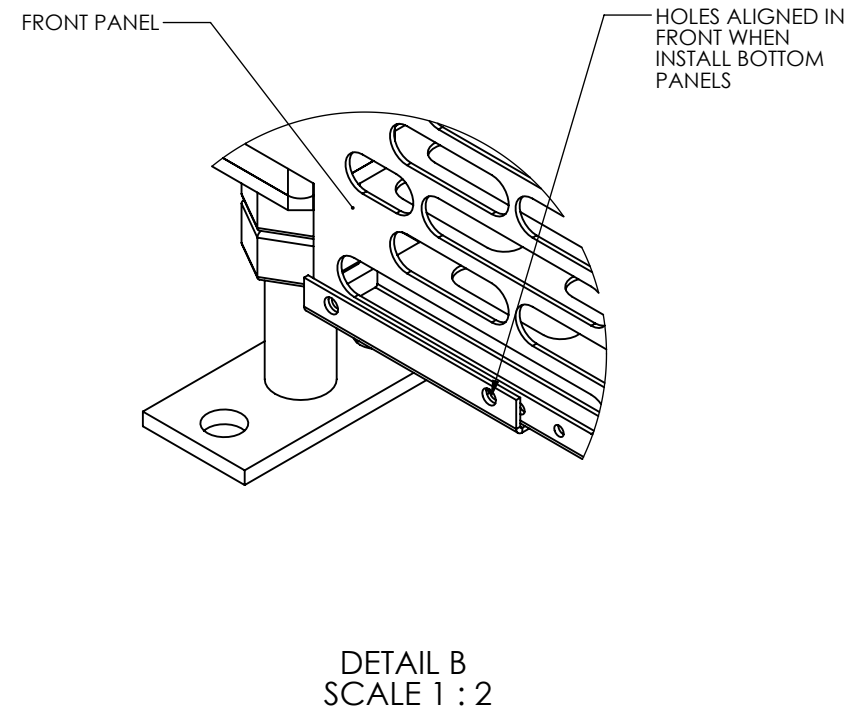
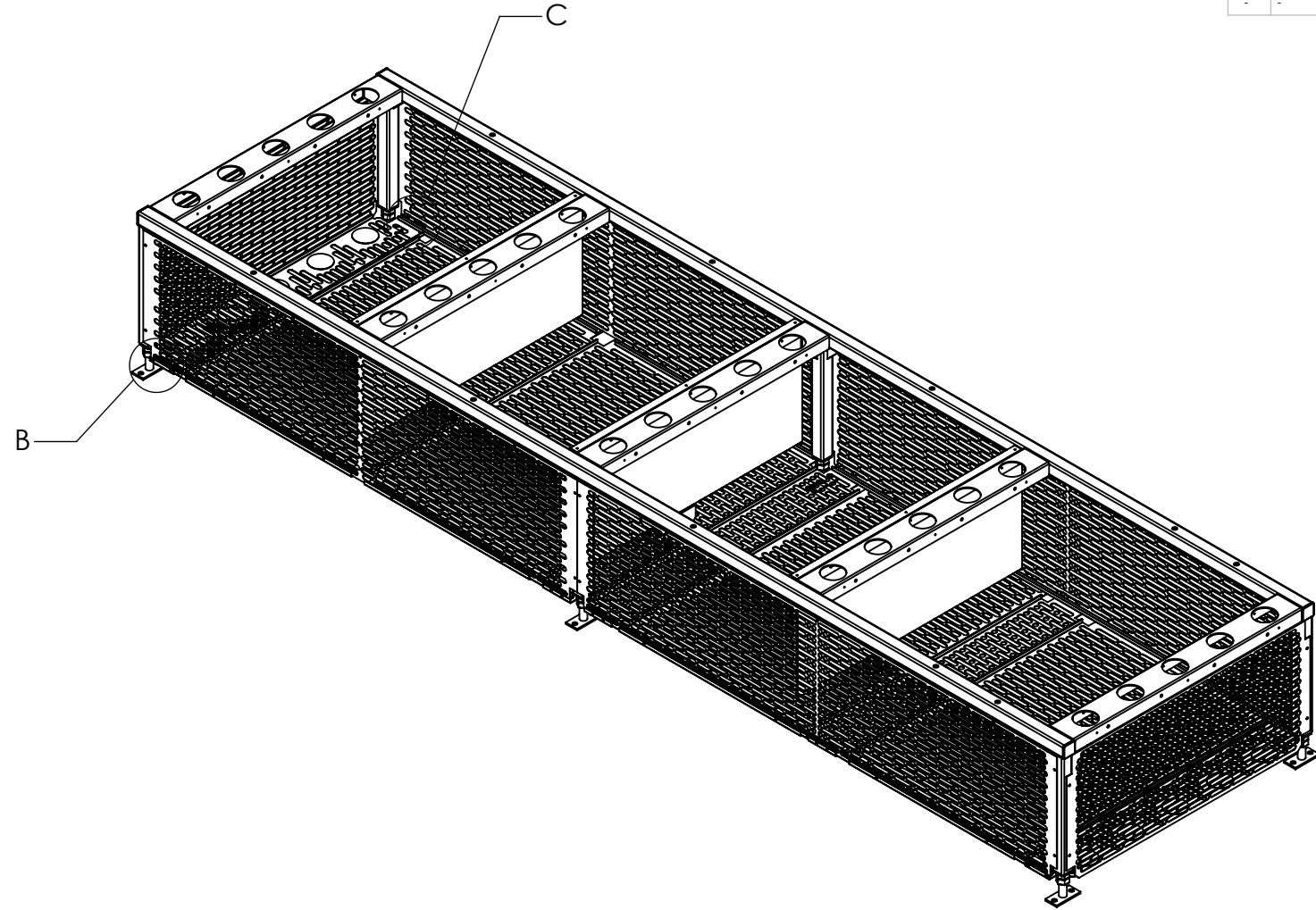
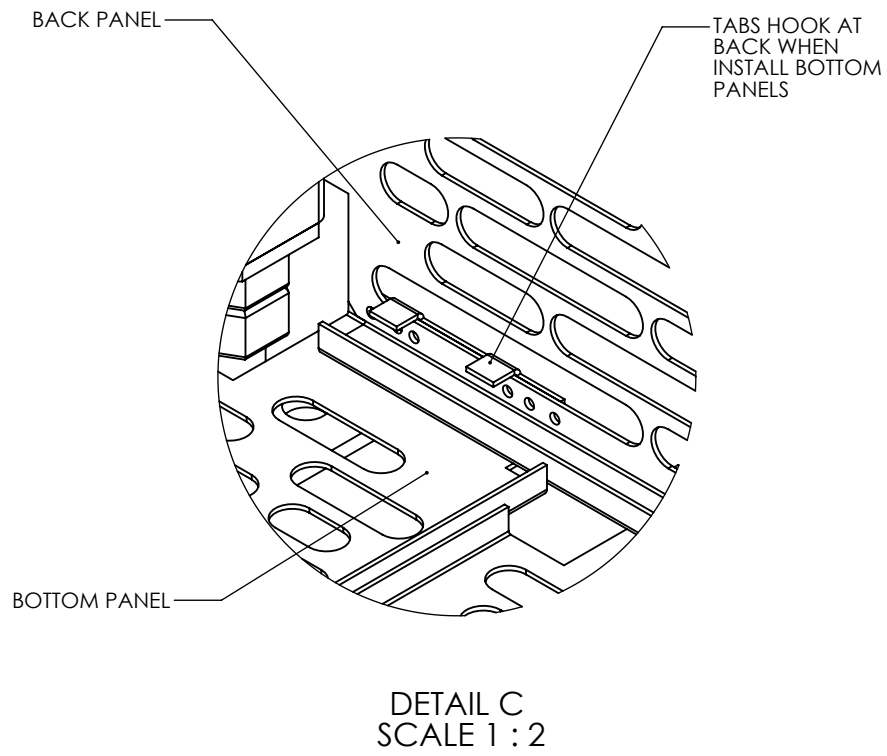

NOTE

1. PUT FLOOR STAND UPSIDE DOWN. INSTALL SIDE, FRONT AND BACK PANELS;
2. WHEN INSTALL BOTTOM PANELS, HOOK UP THE TABS WITH BACK PANELS
3. ALIGN HOLES ON BOTTOM PANELS WITH FRONT PANEL HOLES. SECURE WITH FASTENERS.

NOTES:

UNLESS OTHERWISE SPECIFIED
DIMENSIONS ARE IN INCHES
TOLERANCES:
FRACTIONAL $\pm 1/8$
ANGULAR: $\pm 0.5^\circ$ BEND $\pm 2^\circ$
DECIMAL
XXX = $\pm .010$
XX = $\pm .020$
X = $\pm .030$
HOLE DIA. $+.003/-0.000$

THIRD ANGLE PROJECTION



	BY	DATE
DRAWN	I.Z.	02/16/2010
CHECKED	P.S.	02/16/2010
CNC PROGRAM		
FINISH:	X	
MATERIAL	N/A	THICKNESS N/A



FINAL ASSEMBLY
FLOOR STAND, DOWN FLOW, CHILLED WATER COOLING
ONLY, 12'-24", 119 TO 136 KW, WITH OSHA GUARD

PART NAME		SPDF-O-J	
SIZE	DWG. NO.	REV.	SEE TABLE
B	SPDF-O-J		
BD	N/A	K	SCALE: 1:20 SHEET 2 OF 2

CONFIDENTIAL: THE COPYRIGHT OF THIS DOCUMENT IS RESERVED BY CLIMATEWORX. THIS DOCUMENT IS ISSUED ON THE CONDITION THAT IT IS NOT COPIED, REPRODUCED OR DISCLOSED TO ANY OTHER PARTY WITHOUT WRITTEN CONSENT OF CLIMATEWORX.